

OPERATION MANUAL



SAND BLAST CABINET

Model. SBC-990

Order Code S305

Edition No : SBC-990-1

Date of Issue : 08/2022

MACHINE DETAILS

MACHINE	<input type="text" value="SAND BLAST CABINET"/>
MODEL NO.	<input type="text" value="SBC-990"/>
SERIAL NO.	<input type="text"/>
DATE OF MANF.	<input type="text"/>

DISTRIBUTED BY



www.machineryhouse.com.au

www.machineryhouse.co.nz

NOTE:

This manual is only for your reference. At the time of the compiling of this manual every effort to be exact with the instructions, specifications, drawings, and photographs of the machine was taken. Owing to the continuous improvement of the HAFCO METALMASTER machine, changes may be made at any time without obligation or notice. Please ensure the local voltage is the same as listed on the specification plate before operating any electric machine.

SAFETY SYMBOLS

The purpose of safety symbols is to attract your attention to possible hazardous conditions



WARNING

indicates a potentially hazardous situation causing injury or death



CAUTION

indicates an alert against unsafe practices.

Note:

Used to alert the user to useful information

NOTE:

In order to see the type and model of the machine, please see the specification plate. Usually found on the back of the machine. See example (Fig.1)

Fig.1

PRODUCT SPECIFICATIONS	
Model: SBC-990	Voltage: 240V/50Hz
Capacity: 680L/min	Motor: 1200W
Nett Weight: 157kg	FLC:5.5A
MFG Date:	
Serial No:	<input type="text"/>
Imported by www.machineryhouse.com.au	Made in China www.machineryhouse.co.nz

C O N T E N T S:

1. GENERAL MACHINE INFORMATION	
1.1 Specifications.....	4
1.2 Accessories Includes.....	4
1.3 Identification.....	5
2. SAFETY	
2.1 General Metalworking Machine Safety.....	6
2.2 Specific Safety For Sand Blast Cabinet.....	9
3. POWER SUPPLY	
3.1 Electrical Requirements.....	10
3.2 Full Load Current.....	10
4. SETUP	
4.1 Unpacking.....	11
4.2 Clean Up.....	11
4.3 Site Preparation.....	11
4.4 Lifting Instructions.....	11
4.5 Anchoring To The Floor.....	12
4.6 Assembly.....	13
4.7 Air Supply.....	16
5. OPERATION	
5.1 Controls.....	17
5.2 Basic Operation.....	18
5.3 Blasting Media.....	20
5.4 Accessories & Consumables.....	20
5.4 Troubleshooting.....	21
6. MAINTENANCE	
6.1 Schedule.....	22
6.2 Cleaning The Filter.....	22
Spare Parts.....	23
Risk Assessment Sheets.....	29

**WARNING**

The machine is the sole responsibility of the owner for its safe use. This responsibility includes but is not limited to proper installation in a safe environment, personnel training, proper inspection and maintenance, manual availability and comprehension. The manufacturer will not be held liable for injury or property damage from negligence, improper training, machine modifications or misuse.

1.1 SPECIFICATION

Order Code	S305
MODEL	SBC-990
Approx. Inside Cabinet Size (L x W x H) (mm)	1175 x 885 x 625-845
Internal Light (type)	LED Light
Recommended Free Air Delivery @ 100psi (LPM)	680
Suggested Operating Air Pressure Range	60 ~ 125psi
Maximum Air Pressure	125psi
Recommended Air Supply ..	5 ~ 35 CFM
Dust Collector Filter Rating	5 microns
Floor Space with Door/Lid Open (L x W x H) (mm)	2340 x 950 x 1650
Shipping Dimension (cm)	133 x 96 x 107
Nett Weight (kg)	157

1.2 ACCESSORIES INCLUDED

Built in 240V vacuum and filter system at rear of sandblast cabinet
 Internal LED lighting system
 Complete tempered glass screen with replacement shields, Gloves, Blast gun & ceramic tips.

Parts List

1. Blast Cabinet
2. Dust Filter
3. Left and Right Table Grate
4. Hopper
5. Stand Top
6. Side Braces
7. Legs
8. PVC Protective Sheets, Nuts & Bolts
9. Regulator and Foot Pedal

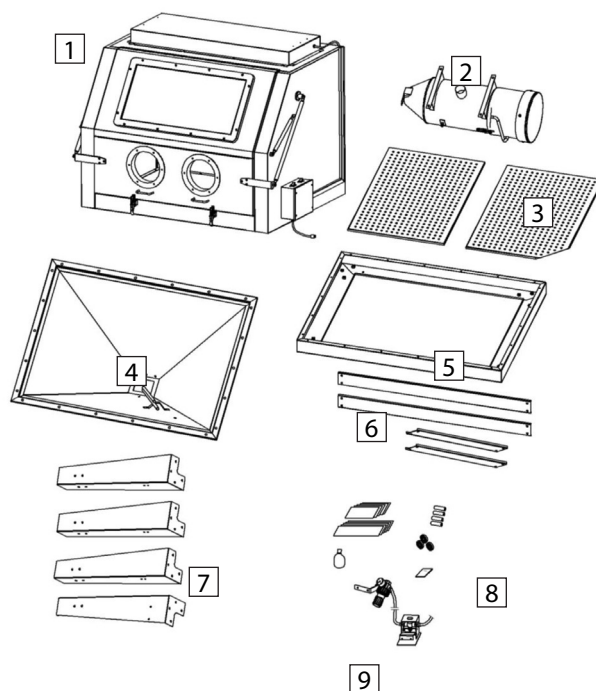

1.3 IDENTIFICATION

Become familiar with the names and locations of the controls and features shown below to better understand the instructions in this manual.



A	Viewing Window	F	Foot Pedal Blasting Switch
B	LED Light Assembly	G	Dust Collector Motor
C	Gloves	H	Gas Strut Door Support
D	ON/OFF Switches	I	Dust Collector
E	Front Access Door Handle	J	Hopper

2.1 GENERAL MACHINE SAFETY

DO NOT use this machine unless you have read this manual or have been instructed in the safe use and operation of this machine.



WARNING

This manual provides safety instructions on the proper setup, operation, maintenance, and service of this machine. Save this manual, refer to it often, and use it to instruct other operators. Failure to read, understand and follow the instructions in this manual may result in fire or serious personal injury—including amputation, electrocution, or death.

The owner of this machine is solely responsible for its safe use. This responsibility includes, but is not limited to proper installation in a safe environment, personnel training and authorization to use, proper inspection and maintenance, manual availability and comprehension, of the application of the safety devices, integrity, and the use of personal protective equipment.

The manufacturer will not be held liable for injury or property damage from negligence, improper training, machine modifications or misuse.



- ✓ Always wear safety glasses or goggles.
- ✓ Wear appropriate safety footwear.
- ✓ Wear respiratory protection where required.
- ✓ Gloves should never be worn while operating the machine controls, and only worn when handling the workpiece.
- ✓ Wear hearing protection in areas > 85 dBA. If you have trouble hearing someone speak from one metre (three feet) away, the noise level from the machine may be hazardous.
- ✓ DISCONNECTION THE MACHINE FROM POWER when making adjustments or servicing.
- ✓ Check and adjust all safety devices before each job.
- ✓ Ensure that guards are in position and in good working condition before operating.
- ✓ Ensure all machines have a start/stop button within easy reach of the operator.
- ✓ Each machine should have only one operator at a time. However, everyone should know how to stop the machine in an emergency.

2.1 GENERAL MACHINE SAFETY Cont.

- ✓ Ensure that keys and adjusting wrenches have been removed from the machine before turning on the power. Appropriate storage for tooling should be provided.
- ✓ Ensure that all cutting tools and blades are clean and sharp. They should be able to cut freely without being forced.
- ✓ Stop the machine before measuring, cleaning or making any adjustments.
- ✓ Wait until the machine has stopped running to clear cuttings with a vacuum, brush or rake.
- ✓ Keep hands away from the cutting head and all moving parts.
- ✓ Avoid awkward operations and hand positions. A sudden slip could cause the hand to move into the cutting tool or blade.
- ✓ Return all portable tooling to their proper storage place after use.
- ✓ Clean all tools after use.
- ✓ Keep work area clean. Floors should be level and have a non-slip surface.
- ✓ Use good lighting so that the work piece, cutting blades, and machine controls can be seen clearly. Position any shade lighting sources so that they do not cause any glare or reflections.
- ✓ Ensure there is enough room around the machine to do the job safely.
- ✓ Obtain first aid immediately for all injuries.
- ✓ Understand that the health and fire hazards can vary from material to material. Make sure all appropriate precautions are taken.
- ✓ Clean machines and the surrounding area when the operation is finished.
- ✓ Use proper lock out procedures when servicing or cleaning the machines or power tools.

DO NOT

- ✗ Do not distract an operator. Horseplay can lead to injuries and should be strictly prohibited.
- ✗ Do not wear loose clothing, gloves, necktie's, rings, bracelets or other jewellery that can become entangled in moving parts. Confine long hair.
- ✗ Do not handle cuttings by hand because they are very sharp. Do not free a stalled cutter without turning the power off first. Do not clean hands with cutting fluids.
- ✗ Do not use rags or wear gloves near moving parts of machines.
- ✗ Do not use compressed air to blow debris from machines or to clean dirt from clothes.
- ✗ Do not force the machine. It will do the job safer and better at the rate for which it was designed.



CAUTION. Before operating any machine, take time to read and understand all safety signs and symbols. If not understood seek explanation from your supervisor.

2.1 GENERAL MACHINE SAFETY Cont.

HAZARDS ASSOCIATED WITH MACHINES include, but are not limited to:

- Being struck by ejected parts of the machinery
- Being struck by material ejected from the machinery
- Contact or entanglement with the machinery
- Contact or entanglement with any material in motion

Health Hazards (other than physical injury caused by moving parts)

- Chemicals hazards that can irritate, burn, or pass through the skin
- Airborne items that can be inhaled, such as oil mist, metal fumes, solvents, and dust
- Heat, noise, and vibration
- Ionizing or non-ionizing radiation (X-ray, lasers, etc.)
- Biological contamination and waste
- Soft tissue injuries (for example, to the hands, arms, shoulders, back, or neck) resulting from repetitive motion, awkward posture, extended lifting, and pressure grip)

Other Hazards

- Slips and falls from and around machinery during maintenance
- Unstable equipment that is not secured against falling over
- Safe access to/from machines (access, egress)
- Fire or explosion
- Pressure injection injuries from the release of fluids and gases under high pressure
- Electrical Hazards, such as electrocution from faulty or ungrounded electrical components
- Environment in which the machine is used (in a machine shop, or in a work site)



WARNING. Machines are safeguarded to protect the operator from injury or death with the placement of guards. Machines must not be operated with the guards removed or damaged.

2.2 SPECIFIC SAFETY FOR BLAST CABINETS

DO NOT use this machine unless you have been instructed in its safe use and operation and have read and understood this manual



Safety glasses must be worn at all times in work areas



Long and loose hair must be contained or restrained



Sturdy footwear must be worn at all times in work areas



Close fitting/protective clothing must be worn



Always wear hearing protection when operating this machine.



A mask must be worn when excessive airborne dust is created

PERSONAL PROTECTION EQUIPMENT. Media blasting presents a real hazard of silicosis and other lung contamination injuries! These injuries are permanent and can get worse over time. If you use media blasting equipment without the proper head gear, eye protection, and respirator, your lungs and eyes may become permanently damaged. **DO NOT** use this blast cabinet unless you know how to use it. Protect yourself correctly, and keep all unprotected bystanders away.

ALWAYS use approved protective equipment and acceptable respirator types.

SAFE MEDIA BLASTING. Do not use system over the rated PSI or lines and seals may burst and cause injury.

SAFE DUST EXPOSURE. To prevent dust exposure, always secure the door(s) before beginning media blasting operations.

LOADING & UNLOADING. To prevent accidental blasting injury, disconnect the air supply before loading or unloading the workpiece from the blast cabinet.

WHEN FINISHED. To prevent accidental blasting injury, disconnect the air supply when finished with the blast cabinet.

SAFE ENVIRONMENT. To avoid media escaping from the cabinet or to prevent an entrapment hazard for animals or children, always close and latch shut the blast cabinet doors when not in use.

CORRECT LIGHTING. To prevent ballast overload and possible fire, only install lamps that are the same voltage and wattage.

MAINTAINING BLAST CABINET. To prevent accidental contamination of shop air, check the blast cabinet for any leaks before use, and reseal immediately.

MAINTAINING COMPONENTS. To prevent accidental contamination or blast injuries, replace tips, hoses, lenses, and gloves when they become worn.



WARNING

Some dust created by power sanding, sawing, grinding, drilling, and other construction activities contains chemicals known to cause cancer, birth defects or other reproductive harm. Some examples of these chemicals are:

- *Lead from lead-based paints.*
- *Crystalline silica from bricks, cement and other masonry products.*
- *Arsenic and chromium from chemically-treated lumber.*

To reduce your exposure to these chemicals: Work in a well ventilated area with protection

3. POWER SUPPLY

3.1 ELECTRICAL INSTALLATION

Place the machine near an existing power source. Make sure all power cords are protected from traffic, material handling, moisture, chemicals, or other hazards. Make sure there is access to a means of disconnecting the power source. The electrical circuit must meet the requirements for 240V.

NOTE : The use of an extension cord is not recommended as it may decrease the life of electrical components on your machine.

ELECTRICAL REQUIREMENTS

Nominal Voltage.....	240V
Cycle.....	50 Hz
Phase.....	Single Phase
Power Supply Circuit.....	10 Amps
Full Load Current.....	5.8 Amps

(Full load current rating is also on the specification plate on the motor.)

3.2 FULL-LOAD CURRENT RATING

The full-load current rating is the amperage a machine draws when running at 100% of the output power. Where machines have more than one motor, the full load current is the amperage drawn by the largest motor or a total of all the motors and electrical devices that might operate at one time during normal operations.

Full-Load Current Rating for these machine at 240V is 5.8 Amps

It should be noted that the full-load current is not the maximum amount of amps that the machine will draw. If the machine is overloaded, it will draw additional amps beyond the full-load rating and if the machine is overloaded for a long period of time, damage, overheating, or fire may be caused to the motor and circuitry.

This is especially true if connected to an undersized circuit or a long extension lead. To reduce the risk of these hazards, avoid overloading the machine during operation and make sure it is connected to a power supply circuit that meets the requirements.



4 SETUP

4.1 UNPACKING

This machine was carefully packaged for safe transport. When unpacking, separate all enclosed items from packaging materials and inspect them for shipping damage. If items are damaged, please contact your distributor.

NOTE: *Save all the packaging materials until you are completely satisfied with the machine and have resolved any issues with the distributor, or the shipping agent.*

When unpacking, check the packing list to make sure that all parts shown are included. If any parts are missing or broken, please contact the your distributor.

4.2 CLEAN - UP

The unpainted surfaces of the machine have been coated with a waxy oil to protect them from corrosion during shipment. Remove the protective coating with a solvent cleaner or a citrus based degreaser.

Optimum performance from your machine will be achieved when you clean all moving parts or sliding contact surfaces that are coated with rust prevented products.

It is advised to avoid chlorine based solvents, such as acetone or brake parts cleaner, as they will damage painted surfaces and strip metal should they come in contact. Always follow the manufacturer's instructions when using any type of cleaning product.

4.3 SITE PREPARATION

When selecting the site for the machine, consider the largest size of workpiece that will be processed through the machine and provide enough space around the machine for operating the machine safely. Consideration should be given to the installation of auxiliary equipment. Leave enough space around the machine to open or remove doors/covers as required for the maintenance and service as described in this manual.

It is recommended that the machine is anchored to the floor to prevent tipping or shifting. It also reduces vibration that may occur during operation.

4.4 LIFTING INSTRUCTIONS



WARNING

This machine is extremely heavy.

Serious personal injury may occur if safe moving methods are not followed. To be safe, you will need assistance and power equipment when moving the shipping crate and removing the machine from the crate.



On the day that the machine arrives, make sure that a forklift or lifting device, with sufficient capacity is available to unload the machine from the vehicle. Ensure access to the chosen site is clear and that doors and ceilings are sufficiently high and wide enough to receive the machine.

4.5 ANCHORING TO THE FLOOR

The machine is best mounted on a concrete slab. Masonry anchors with bolts are the best way to anchor machinery, because the anchors sit flush with the floor surface, making it easy to unbolt and move the machine later, if needed. (Fig. 4.4)

Machine Mounting Options

Although it is not required Hafco recommends that you secure your machine to the floor. Masonry anchors with bolts are the best way to anchor machinery, because the anchors sit flush with the floor surface, making it easy to unbolt and move the machine later, if needed. (Fig. 2) Other methods of mounting is the use of machine mounts which also help with the levelling of the machine and isolating vibration. (Fig. 3)

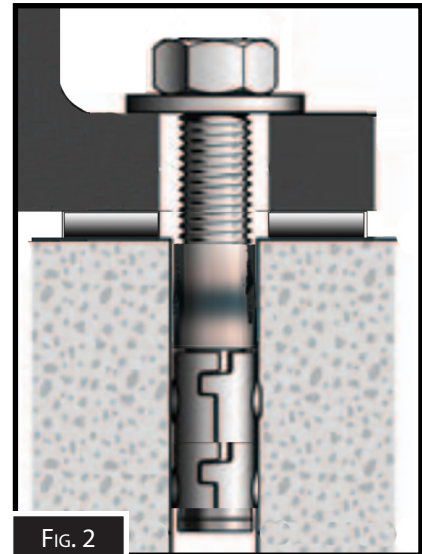

Typical fasteners for mounting to concrete floors. (Fig. 4)



WARNING. If the machine is to be hardwired to the power source, we strongly recommend securing your machine to the floor. Consult with your local electrician to ensure compliance with local codes.

4.6 ASSEMBLY

The machine must be fully assembled before it can be operated. First clean any parts that are coated in rust preventative to ensure the assembly process can proceed smoothly.

To assemble the blast cabinet:

1. Unpack the blast cabinet close to where it will be installed
2. Lay a sheet of cardboard on the floor to protect the blast cabinet, and with the help of an assistant, place the cabinet on its side or back.
3. Assemble the stand using the M8 x 20mm bolts, washers and spring washers. Make sure that Leg "B" with the holes for the regulator, is assembled to the front left hand side.(Fig.5)
4. Place the stand in an upright position and place the bottom section of the hopper on the stand (Fig. 6)
5. With the help of other people, lift the top section of the blast cabinet onto the stand. Open the double fold door to allow for access and secure with the 22 pieces of M6 x 16mm round head screws and washers. (Fig. 7)

Note: Ensure that The front of the cabinet is facing towards leg "B"

6. Attach the bracket with the pressure gauge to the left front leg with the two M6 x 12mm screws, lock washers and nuts. (Fig. 8)

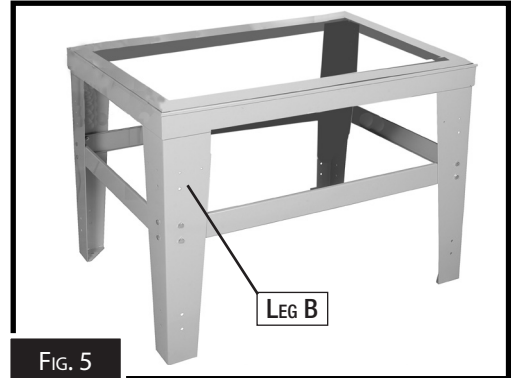
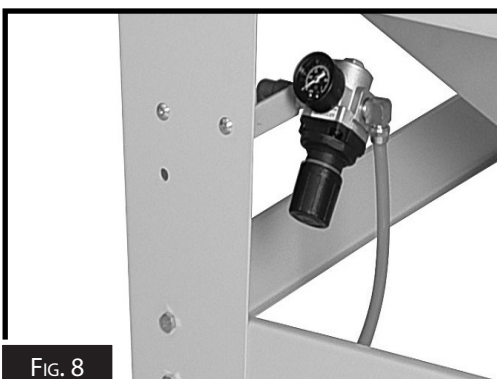
**FIG. 5****FIG. 6****FIG. 7****FIG. 8**

4.6 ASSEMBLY Cont.

12. Connect the foot valve output line to the fitting located on front right hand side of the hopper. (Fig. 9)

13. Position the foot pedal between front legs of the blast cabinet.

14. Using four M6 x 12mm cabinet screws and washers, fasten the dust collector to the rear of the cabinet, so the suction port protrudes through the hole cut into the back of the cabinet. (Fig.10)

15. Place a bead of chalking around the protruding pipe to seal it To provide access to full circumference of dust collector suction pipe, remove the inside right baffle. (Fig. 11)

16. Place the motor on top of the canister and secure it with the catches. Plug the dust collector into the power socket protruding from the back of the control box. (Fig. 12)

17. Unlatch the dust collector motor and lift the cartridge out of the dust collector and set it aside.

18. Working from inside of the dust collector, insert the plunger through the dust collector wall so it can be seen protruding from the outside of the dust collector.

19. Place the spring on the plunger shaft, and thread the lock nut and knob onto the plunger, (Fig. 13)

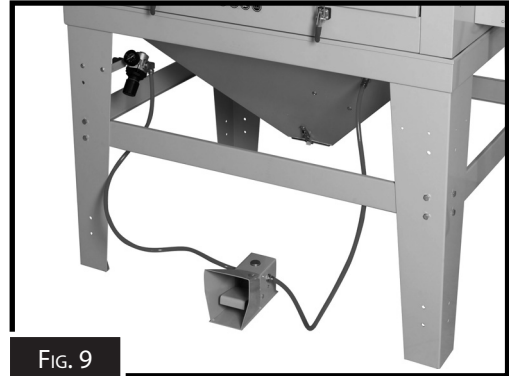

FIG. 9



FIG. 10



FIG. 11



FIG. 13



FIG. 12

4.6 ASSEMBLY Cont.

20. Place the work tables into the cabinet, so the work table with a corner cut off is positioned at the front right corner of the blast cabinet. (Fig. 14)
21. Route the blast gun hoses through the notch in the right side of the table, and hang blast gun on its hook on right side of cabinet wall, (Fig. 15)
22. Check that the plastic PVC dust sheets have been attached to the inside of the cabinet viewing window and the lamp window. If blasting operations begin with out these dust sheets installed, media will permanently etch the window glass and require the glass to be replaced. (Fig. 16)
23. Select the type of media required and pour the desired amount into the cabinet through front door.
24. Allow the silicone sealant to fully cure. If the sealant is not cured, when machine is turned ON and media blasting begins, the seal may be broken, causing leakage.
25. Inspect all seals, hose clamps, glove clamps, and window seals for loose fittings, cracks or leaks. Correct as required.

**CAUTION**

It is impossible to cover all possible safety guidelines. Every workshop environment is different. Always consider safety first, as it applies to the individual working conditions. Always use this and any other machinery with caution and respect. Failure to do so could result in, serious personal injury or. damage to equipment

4.7 AIR SUPPLY

Air compressors are normally rated with an output measurement of either Cubic Feet or Litres per minute of compressed air which affects sandblasting due to sandblasting cabinets requiring a large volume of air for them to perform at their optimum.

The compressors output of air refers to the volume or amount of compressed air an air compressor can produce based on the size of the pistons, within the compressor pump, & the horsepower of the motor to drive this pump. PSI or pounds per square inch is a measurement of pressure which is completely different to CFM/LPM (volume) & it is the larger volume of air that is required for a sandblast cabinet & not high pressure that is required.

Some abrasive blasting cabinets can operate on a 240-volt air compressor, but these generally have a smaller size sandblasting gun which do not require a large volume of air to operate correctly but they also take longer to sandblast an item due to the limited size of the nozzle & the amount of blast media the gun is able to expel during blasting. A larger gun will blast much more quickly but it will also require a larger volume of air to perform at its optimum usually requiring a larger 415-volt air compressor with sufficient output of air to blast effectively & efficiently.

It is recommended that the minimum diameter hose used, to connect the compressor to the sandblast cabinet, be at least 3/4" (19mm) hose to ensure adequate flow of air volume to your cabinet. It is also recommended that a suitable water separator or filter be installed close to the sandblast cabinet to ensure the air, coming from the air compressor, is clean & dry.

Connecting To The Air Supply

When connecting the air supply, remove any in-line oilers, make the supply line long enough to allow the compressed air to fully cool before it reaches the gun. Install an in-line water separator or air dryer. Tilt the air supply lines slightly back toward the compressor so residual condensation in the lines will run back to the tank instead of the media blasting unit.

1. Connect the air line from the compressor to the regulator that is fitted to the leg of the blast cabinet. (Fig. 17)

Note: If after operating the machine for the first time, the regulator gauge needle drops more than a few PSI when you press the foot pedal, check that the air supply is not restricted.

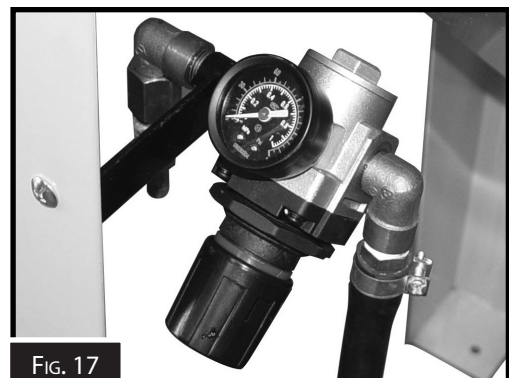

CAUTION Compressed Air is Dangerous and can cause Death or Injury if misused. Always bleed off the airline before disconnecting from the compressor or machine. DO NOT use compressed air to blow dust from clothes

5. OPERATION

This machine may perform many types of operations that are beyond the scope of this manual. Many of these operations may be dangerous or deadly if performed incorrectly.

The instructions in this section are written with the understanding that the operator has the necessary knowledge and skills to operate this machine. If at any time you are experiencing difficulties performing any operation, stop using the machine!

If you are an inexperienced operator, we strongly recommend that you read books, trade articles, or seek training from an experienced operator before performing any unfamiliar operations.

Above all, your safety should come first!

5.1 CONTROLS

The purpose of this control overview is to provide the novice machine operator with a basic understanding of how the machine is used during operation, and the machine controls and what they do. It also helps the operator to understand if they are discussed later in this manual.

NOTE: DO NOT start the machine until all of the setup instructions have been performed. Operating a machine that is not setup may result in malfunction or unexpected results that can lead to serious injury, death or damage to the machine or property.

1. **LIGHT ON/OFF Switch:** Switches on the light, in the cabinet. (Fig. 18)
2. **DUST COLLECTOR Switch:** Switches ON/OFF the dust collector. (fig. 18)
3. **Pressure Gauge:** Displays the air pressure supplied to the machine. (Fig. 19)
4. **Air Pressure Adjustment:** Adjusts the air pressure supplied to the machine. (Fig. 19)
5. **Foot Switch:** Activates the blast gun when pressed. (Fig. 20)

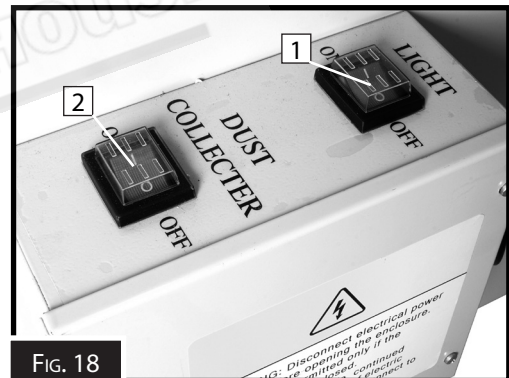

FIG. 18

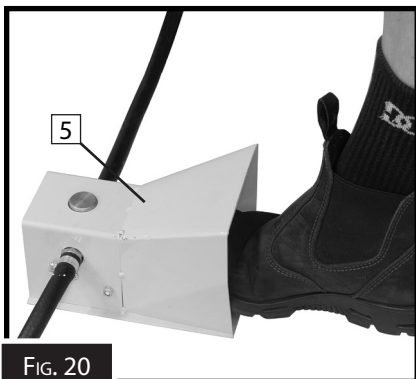

FIG. 20

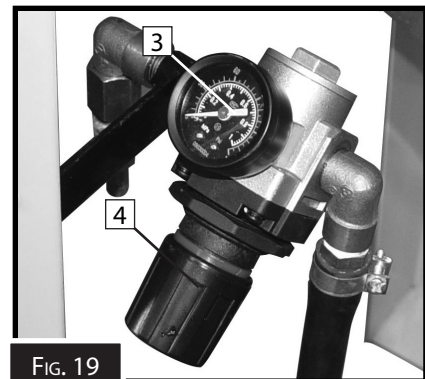

FIG. 19

5.2 BASIC OPERATION

Listed below is the order in which a normal operation for the SBC-990 Blast Cabinet is carried out.

NOTE: Before using the blast cabinet the first time, fit the window protective film to the inside of the light and glass window.

1. Check the window protective film for holes or excessive etching. Replace the sheets BEFORE they are worn through and the window is damaged. (Replacement Film Order Code 7SC0024 and 7SC0030)
2. Inspect all fittings and hoses for leaks. Inspect for damaged or leaking door seals. Make sure water separators are drained and make sure the dust collector is empty and the filter is clean.
3. Put on safety goggles and a respirator.

NOTE: To reduce your exposure to Dust Particles: Work in a well ventilated area, and work with approved safety equipment, such as those dust masks that are specially designed to filter out microscopic particles.

4. Select the blasting media and load it through one of the doors so that it is approximately 150mm above the metering valve.

NOTE: Never use media that contains free silica, as this is a leading cause of silicosis.

5. Select and install the required tip into the blast gun. (Usually 6mm) (Fig. 21)

NOTE: Tips available for this machine are 6mm and 7mm. As a general rule, your nozzle orifice minimum should be 3 times the size of the grit. When media blasting thin materials made of aluminum, copper, brass, wood, or other delicate parts, select the correct media and begin blasting at a low pressure, such as 45 PSI. Next, slowly increase the air pressure until you achieve the finish required. When using some types of glass bead media, you may have to keep the operating pressure between 50-80 PSI, or the media will break down prematurely.

Some media like silicon carbide and aluminium oxide can withstand pressures of up to 120 PSI on this machine; however, most media blasting operations should occur at 80 PSI.

6. Turn the regulator knob to adjust the air pressure to the desired setting. This is a trial and error process, but a good place to start is a pressure between 60 and 80 PSI. (Fig. 22)



FIG. 21



FIG. 22

5.2 BASIC OPERATION Cont.

Note: Trial and error is the best way to sort out the adjustments for the type and amount of media required. Restrict the metering valve too much, the gun will pulsate and a low velocity rich media spray will result. If the metering valve screw is opened too far, the gun will be noisy and a lean media spray will result. (Fig. 23)

7. Clean the workpiece of any oil or grease and place in the blast cabinet. Close the doors, then move the latches until the doors are completely locked.
8. Push the power switch ON, to start the dust collector and turn ON the work lamp. (Fig. 22)
9. Grip the hand gun, then point the blast gun tip at the workpiece at an angle of 45° to 60°.

NOTE! Point the gun if possible in such a way that the ricocheting spray of abrasive will not contact the window.

10. Slowly press the foot pedal and abrasive media will begin spraying from the blast gun tip. Move the blast gun in a slow circular motion.
11. During the operation, periodically push the canister plunger in until it stops, then let your thumb slide off the button so the spring slaps the plunger back against the canister wall. This causes vibration that knocks off the material which is caked on to the outside of the filter. When used for prolonged periods, service the dust collector filter every five hours of cabinet use, (Fig. 23)
12. The blasting media can be changed by releasing the bottom flap in the base of the machine. (Fig. 24)

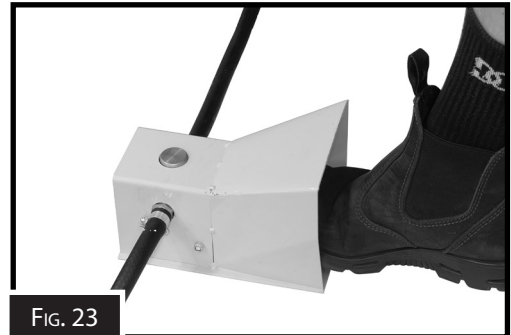

FIG. 23



FIG. 24

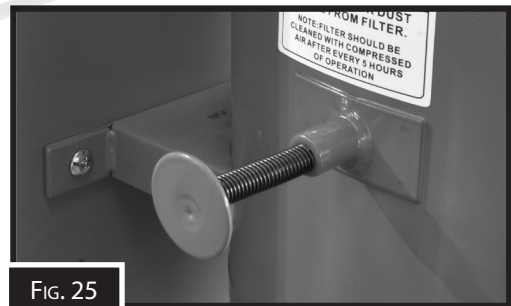

FIG. 25

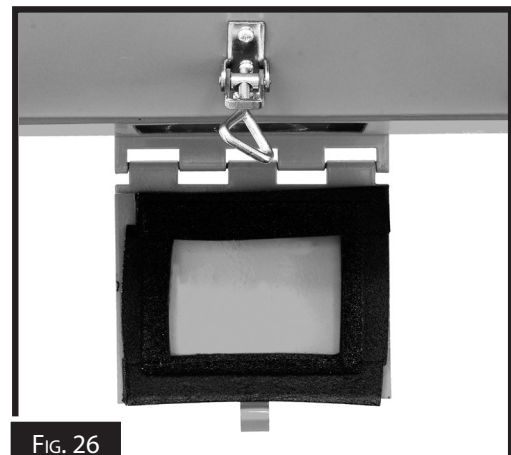

FIG. 26



WARNING

NEVER use the sand blast cabinet with the doors open, or point the gun at yourself or anyone else. When servicing any part of this machine disconnect the power and the air hose. Ignoring this warning may lead to severe injury.

5.3 BLASTING MEDIA

Using low-cost media, such as basic builder’s sand or play sand, is not recommended since sand is dull and does not have the cutting power. Excellent productivity can be achieved using sharp media listed below.

Garnet

Depending on your required finish, there is an ideal garnet grain size for your job. Here’s what to know. For general applications when a surface profile above 75 microns is specified, the 30/60 mesh garnet abrasive is the ideal industry standard garnet grade.

When you remove thick, soft coatings, the surface may absorb the energy before the garnet grains achieve full impact potential.

Therefore, the heavier features of larger grain garnet can be more effective. For this application 20/40 grit size is available.

Inda Glass Bead

Bead blasting is one type of shot blasting. This process releases, at high pressure, fine glass beads to clean or finish a surface. In this process, a bead blaster shoots bead-shaped media from a high-pressured tool towards the material’s surface. A bead blast finish aims to leave a smooth, shiny, and cleaner surface.

5.4 ACCESSORIES & CONSUMABLES

SANDBLASTING BEADS -
GARNET
20 - 40 COARSE BEADS 25KG
ORDER CODE S295



SANDBLASTING BEADS -
GARNET
80 FINE BEADS 25KG
ORDER CODE S293



Sandblasting Beads -
Inda
-300 + 106 INDA (GLASS BEAD)
25KG
ORDER CODE S297



#2 - NOZZLES
6.0MM PKT 2
SUITS SB-420
ORDER CODE 3SC0206

7.0MM PKT 2
SUITS SB-420
ORDER CODE 3SC0207



#1~7 REPLACEMENT
SANDBLAST GUN
SUITS: SB-420
ORDER CODE 3SC0300



#25 REPLACEMENT
PVS SHEETS
LIGHT FILM
SUITS: SB-420 PKT 5
600 x 100MM
ORDER CODE 3SC0005



5.4 ACCESSORIES & CONSUMABLES

#15 REPLACEMENT
GLOVES
SUITS: SB-420 PAIR
ORDER CODE 2SC0035



#25 REPLACEMENT
PVS SHEETS
SUITS: SB-420 PKT 5
550 x 250MM
ORDER CODE SC004



CYCLONE DUST COLLECTOR

A high efficiency Cyclone Dust Collector, with two stage dust cleaning system.

Powerful extraction fan providing large dust vacuum, ideally equipped for sandblaster cabinet.

Noise Level: 75dB@ 1m

Dust Collecting Capacity: 2.9 kg/h

Electrical Requirements: 240 Volt, 50Hz, 10 amp

ORDER CODE S310



5.5 TROUBLESHOOTING

- 1. Blast Gun.** After 10 to 12 hours of blasting time, the Nozzle should be checked. If it shows uneven wear it should be turned 1/4 turn every 10 hours of use. Replace as needed.
- 2. Caking of media.** Media caking is caused by moisture in the air supply or from oily or greasy parts. If not corrected the media will not flow evenly and will block the system. Check the air supply. If water is present, install a quality moisture trap. If oily or greasy parts are being blasted, degrease and dry the part first.
- 3. Reverse pressure.** If the media stops flowing use an object to plug the Nozzle and press the Foot Pedal down for about two seconds. This will cause the system to back blast. This will help loosen any clogs. DO NOT use a finger to block the gun
- 4. Blast Gun air pressure drop.** Turn the Air Regulator Knob and set the air pressure to 80 PSI as indicated on the Pressure Gauge. This could also indicate the air supply hose is too small, The air supply line should be 12mm diameter or larger.
- 5. Poor visibility** (viewing window). The Glass Window is equipped with a clear plastic protector on it and may become pitted. If necessary, replace the plastic protector and/or Glass Window.
- 6. Poor media flow.** Check for moisture. Holes in media hose will also cause poor media delivery. If necessary, replace the hose. Debris in the media can also cause slow media flow. Replace or screen media.

6 MAINTENANCE

It is very important that regular maintenance of the equipment is carried out. The operators need to of follow the daily maintenance procedures.
For optimum performance from this machine, the maintenance schedule listed below and in this section must be followed.

6.1 SCHEDULE

Daily Check

- Loose mounting bolts or fasteners.
- Worn, frayed, cracked, or damaged wires.
- Damaged ON/OFF button
- Push the canister plunger and release to remove caked on dust in the filter.
- Check and clean if necessary filter cartridge
- Any other condition that could hamper the safe operation of this machine

Monthly Check:

- Check all fasteners and clamps are tight.
- Inspect suction lines carefully for spots that collapse or leak during operation.
- Clean/vacuum dust buildup from inside cabinet and off the motor.
- Empty cabinet, wipe down inside and inspect for leaks or damage.
- Cover windows and repaint bare metal portions of cabinet.
- Inspect work gloves for holes or wear.
- Remove the filter and clean or replace as require

6.2 CLEANING THE FILTER

For major cleaning or replacement of the filter,

1. DISCONNECT THE MACHINE FROM THE POWER.
2. Unplug the power to the motor and unlatch the top of the dust collector and remove the motor, then the filter element. (Fig. 25)
- 3 Inspect all sealing foam and replace as required.
4. Clean the filter canister pleats outside in the open by carefully blowing it from the inside out with compressed air.
5. If usability of the filter is in question, or any holes or tears exist, replace it.



FIG. 25



Warning When cleaning the cabinet or the filter, wear a respirator and safety goggles. Failure to comply can cause serious personal injury.

SPARE PARTS SECTION

SAND BLAST CABINET

Model. SBC-990

Order Code S305

Edition No : SBC-990-1

Date of Issue : 08/2022

The following section covers the spare parts diagrams and lists that were current at the time this manual was originally printed. Due to continuous improvements of the machine, changes may be made at any time without notification.

HOW TO ORDER SPARE PARTS

1. Have your machines model number, serial number & date of manufacture on hand, these can be found on the specification plate mounted on the machine
2. A scanned copy of your parts list/diagram with required spare part/s identified.

NOTE: SOME PARTS MAY ONLY BE AVAILABLE AS AN ASSEMBLY

3. Go to www.machineryhouse.com.au/contactus and fill out the inquiry form attaching a copy of scanned parts list.

SPARE PARTS DIAGRAM 1

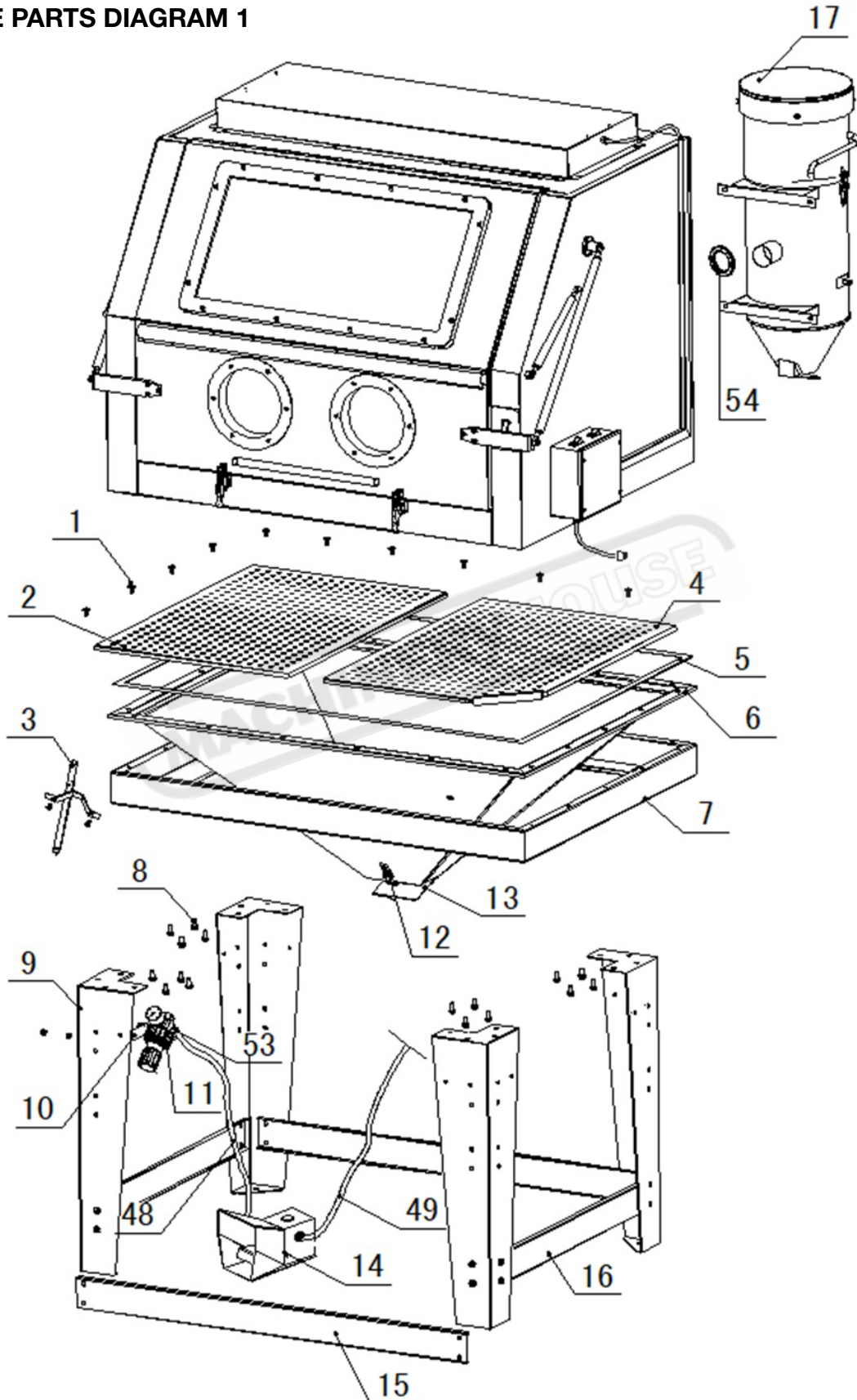

SPARE PARTS DIAGRAM 2

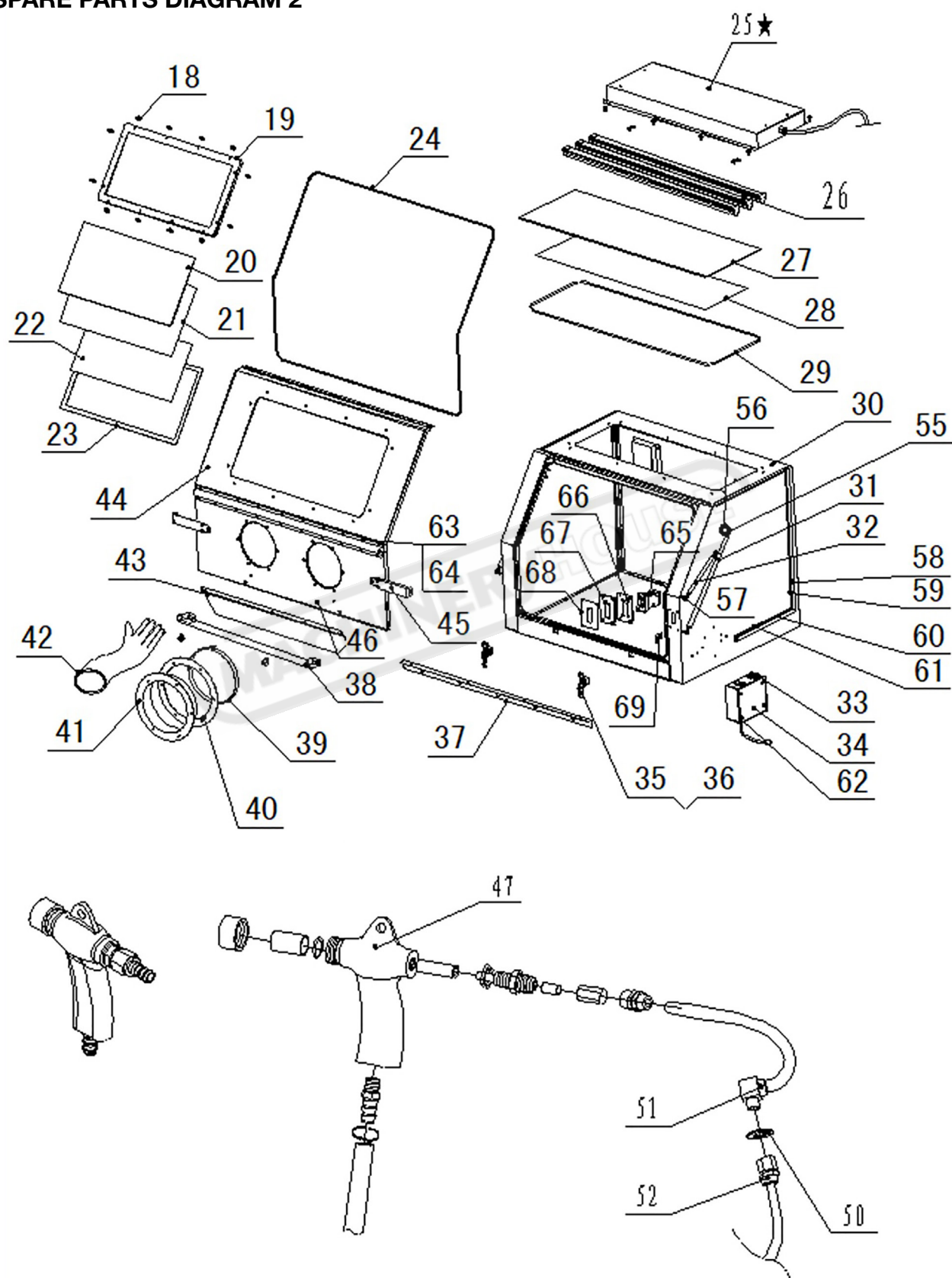

OPERATION MANUAL

SPARE PARTS LIST Cabinet

Item	Factory Code	DESCRIPTION		Qty
1	201020028	ROUND HEAD CROSS SCREW	M6*12	22
	201050003	FLAT WASHER	Ø6* Ø12*1	22
2	405020672	LEFT GRID		1
3	405020039	SUCTION SAND HOSE		1
4	405020659	RIGHT GRID		1
5	206050009	SEALING TAPE	Ø3.0*22	5
6	405020751	BIG FUNNEL		1
7	405020614	BRACKET		1
8	201030019	HEX.SCREW	M8*20mm	32
	201050062	FLAT WASHER	Ø8* Ø16*1.5	32
	201050013	SPRING WASHER	M8	32
9	405020615	LEG		4
10	405020331	PERMANENT SEAT OF PNEUMATIC DEVICE		1
11	204020028	PRESSURE REGULATING VALVE	AR3000-03 0-150Psi	1
12	407020028	ASSEMBLED LATCHES		3
13	405020324	WELDED COVER BOARD FOR FALLING SAND		1
14	407020323	PNEUMATIC DEVICE OF FOOT PEDAL		1
15	403030172	LEG REINFORCES 1		2
16	401010112	LEG REINFORCES 2		2
17	407020416	DUST COLLECTOR	230V (1.73M 3GTJC)	1
18	201020134	ROUND HEAD CROSS SCREW	M6*32	12
19	407020240	BRACKET OF VIEWING WINDOW		1
20	206030011	GLASS BOARD OF VIEWING WINDOW	740*360*1.5	1
21	206030010	GLASS OF VIEWING WINDOW	730*360*5	1
22	206010188	PE FILM OF VIEWING WINDOW	PE	6
23	206050009	SEALING TAPE OF VIEWING WINDOW	3.0*22	
24	407010198	RUBBER SEAL STRIP OF FRONT OPENING DOORFRAME	1200L=3600	1
25	405020650	COVER ASS'Y FOR LED LIGHT		1
26	203030020	LED LIGHT		3
27	206030009	GLASS OF LIGHT WINDOW	990*342*5	1
28	206010189	PE FILM OF LIGHT WINDOW	PE	6
29	407010186	RUBBER SEAL STRIP OF LIGHT WINDOW	l=2560(1200)	1
30	407020381	UPPER CABINET		1
31	405020660	MAIN SUPPORT POLES		2
32	205040148	SUPPORT POLE OF AIR SPRINGS	Ø18* Ø8(430mm)*320N	2
33	407020241	ELECTRIC BOX	230V	1
34	403030173	COVER FOR ELECTRIC BOX		1
35	205040125	FRONT DOOR LATCH		2
36	206010121	LATCH SEATS	990#	2
37	405010133	RACK BOARD		1
38	205040451	GRIP	500*18	1
39	407020025	ELEMENTS OF BIG HOOPS		2
40	206020101	MOUNTINNG RING OF GLOVES		2
41	206010008	GLOVES SEAT		2
42	206020001	GLOVES	L=600 C220.350.420.990.1200)	1
43	403030214	SAND BOARD		1
44	405020638	ELEMENTS OF FRONT OPENING DOOR		1
45	403030175	SUPPORT BOARD OF FRONT DOOR		2

SPARE PARTS LIST

Item	Factory Code	DESCRIPTION	Qty	
46	405020634	WELDED BRACKET FOR FRONT DOOR	1	
47	407020324	SAND GUN	1	
48	407010113	AIR HOSE (ORANGE)	Ø12 Ø8*1000	2
49	407010114	AIR HOSE (ORANGE)	Ø12 Ø8*1300	1
50	403020741	LOCK NUT	Ø14* Ø27	1
51	204030053	L-QUICK CHANGE COUPLING (METAL)	PL12-02	1
52	204030046	QUICK-CHANGE COUPLING (METAL)	PCF12-02	1
53	204030055	L-QUICK CHANGE COUPLING (METAL)	PL12-03	1
54	206020086	RUBBER RING	Ø54* Ø82**9.8	1
55	302010065	WASHER	Ø12* Ø4.2*1.5	6
56	406010043	BRACKET FOR MIAN SUPPORT POLE		2
57	302010066	SEAT FOR SMALL POLE	16*32	2
58	402020164	CABLE BOTTOM COVER A		1
59	402020165	CABLE TOP COVER A		1
60	402020166	CABLE BOTTOM COVER B		1
61	402020167	CABLE TOP COVER B		1
62	201020040	SELF-TAPPING SCREW	ST4.2*9.5-C	4
63	403010123	RUBBER BOARD FOR FOLDING DOOR		2
64	407010197	RUBBER BOARD FOR FOLDING DOOR	135*1030 1.5	1
65	204020001	CONTRAL VALVE ASS'Y	G1/2 (990#)	1
66	402020142	FIXING PLATE FOR VALVE		1
67	403010104	SEAL FOR VALVE		1
68	404010064	COVER FOR VALVE		1
69	401010106	FIXING PLATE FOR AIR HOSE		1

SPARE PARTS FOOT PEDAL

Item	Factory Code	SPECS	Qty
1	403020507	XH-SBC420-15-03	1
2	405020333	XH-SBC420-15-01-00JEMC	1
3	405020318	XH-SBC420-15-02-00	1
4	205040427		1
5	201040024	M6 Nut	1
6	201030015	Bolt M6*90mm	1
7	201030085	Screw M5*10mm	2
8	204030051	PC12-04	2

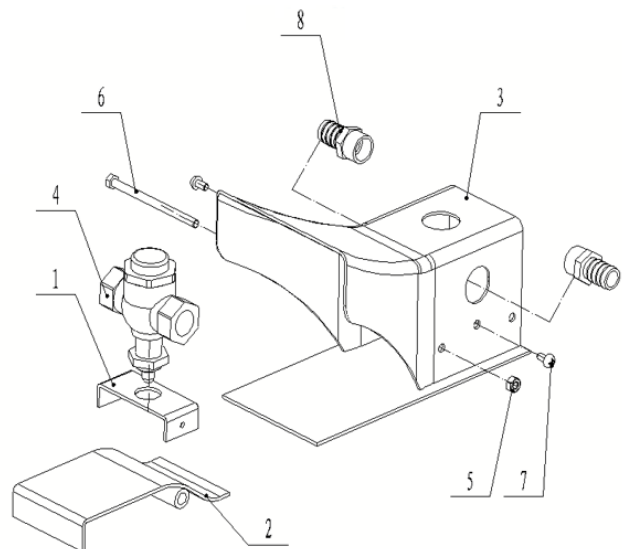

WIRING DIAGRAM

- L PHASE WIRE
- N NEUTRAL WIRE
- PE EARTH WIRE
- F FUSE
- E LUMINAIRE WITH FOUR FLUORESCENT TUBES
- X1 CONNECTOR
- X2 CONNECTOR
- S1 LIGHT SWITCH
- S2 MOTOR SWITCH
- M MOTOR

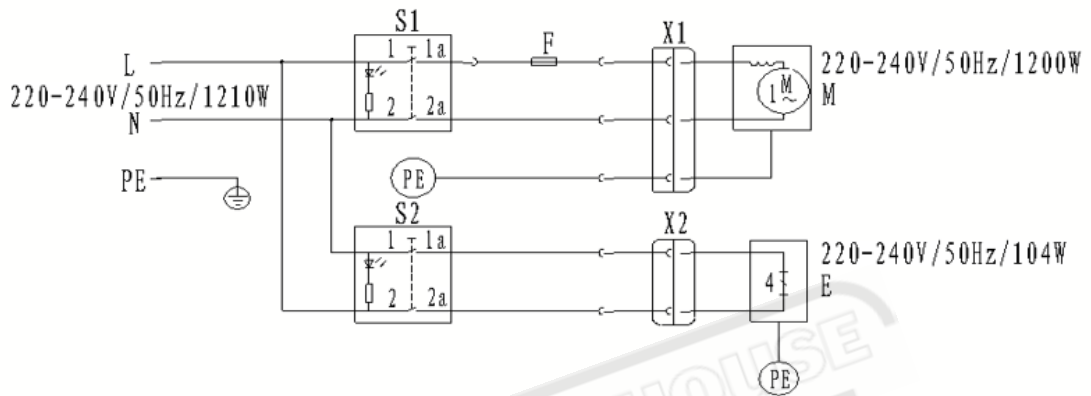

WARNING

General Machinery Safety Instructions

Machinery House
requires you to read this entire Manual before using this machine.

- 1. Read the entire Manual before starting machinery.** Machinery may cause serious injury if not correctly used.
- 2. Always use correct hearing protection when operating machinery.** Machinery noise may cause permanent hearing damage.
- 3. Machinery must never be used when tired, or under the influence of drugs or alcohol.** When running machinery you must be alert at all times.
- 4. Wear correct Clothing.** At all times remove all loose clothing, necklaces, rings, jewelry, etc. Long hair must be contained in a hair net. Non-slip protective footwear must be worn.
- 5. Always wear correct respirators around fumes or dust when operating machinery.** Machinery fumes & dust can cause serious respiratory illness. Dust extractors must be used where applicable.
- 6. Always wear correct safety glasses.** When machining you must use the correct eye protection to prevent injuring your eyes.
- 7. Keep work clean and make sure you have good lighting.** Cluttered and dark shadows may cause accidents.
- 8. Personnel must be properly trained or well supervised when operating machinery.** Make sure you have clear and safe understanding of the machine you are operating.
- 9. Keep children and visitors away.** Make sure children and visitors are at a safe distance for you work area.
- 10. Keep your workshop childproof.** Use padlocks, Turn off master power switches and remove start switch keys.
- 11. Never leave machine unattended.** Turn power off and wait till machine has come to a complete stop before leaving the machine unattended.
- 12. Make a safe working environment.** Do not use machine in a damp, wet area, or where flammable or noxious fumes may exist.
- 13. Disconnect main power before service machine.** Make sure power switch is in the off position before re-connecting.
- 14. Use correct amperage extension cords.** Undersized extension cords overheat and lose power. Replace extension cords if they become damaged.
- 15. Keep machine well maintained.** Keep blades sharp and clean for best and safest performance. Follow instructions when lubricating and changing accessories.
- 16. Keep machine well guarded.** Make sure guards on machine are in place and are all working correctly.
- 17. Do not overreach.** Keep proper footing and balance at all times.
- 18. Secure workpiece.** Use clamps or a vice to hold the workpiece where practical. Keeping the workpiece secure will free up your hand to operate the machine and will protect hand from injury.
- 19. Check machine over before operating.** Check machine for damaged parts, loose bolts, Keys and wrenches left on machine and any other conditions that may effect the machines operation. Repair and replace damaged parts.
- 20. Use recommended accessories.** Refer to instruction manual or ask correct service officer when using accessories. The use of improper accessories may cause the risk of injury.
- 21. Do not force machinery.** Work at the speed and capacity at which the machine or accessory was designed.
- 22. Use correct lifting practice.** Always use the correct lifting methods when using machinery. Incorrect lifting methods can cause serious injury.
- 23. Lock mobile bases.** Make sure any mobile bases are locked before using machine.
- 24. Allergic reactions.** Certain metal shavings and cutting fluids may cause an allergic reaction in people and animals, especially when cutting as the fumes can be inhaled. Make sure you know what type of metal and cutting fluid you will be exposed to and how to avoid contamination.
- 25. Call for help.** If at any time you experience difficulties, stop the machine and call you nearest branch service department for help.

WARNING

Sandblast Cabinet Safety Instructions

Machinery House
requires you to read this entire Manual before using this machine.

- 1. Maintenance.** Make sure the Sandblast Cabinet is turned off and disconnect from the air & main power supply before any inspection, adjustment or maintenance is carried out. Clean dust collection and filters often and repair any suction hose leaks immediately. Replace nozzles, hoses, lenses and gloves when become worn. Check the cabinet for any leaks, and reseal immediately.
- 2. Correct abrasives.** Never use wet abrasives in this Sandblast Cabinet. It is designed for dry abrasives only.
- 3. Leaving a Sandblast Cabinet Unattended.** Always turn the Sandblast Cabinet off before leaving the Sandblast Cabinet. Do not leave the Sandblast Cabinet running unattended for any reason.
- 4. Protecting environment.** Keep Sand blast doors shut when not in use.
- 5. Understand the machines controls.** Make sure you understand the use and operation of all controls.
- 6. Power outage.** In the event of a power failure during use of the machine, turn off all switches to avoid possible sudden start up once power is restored.
- 7. Sandblast Cabinet kPa capacity.** Never use this Sandblast Cabinet over the rated PSI rating.
- 8. Changing the Workpiece.** Disconnect the air supply before loading and unloading the workpiece from the Sandblast Cabinet.
- 9. Hearing protection and hazards.** Always wear hearing protection as noise generated from Sandblast Cabinet and workpiece vibration can cause permanent hearing loss over time.
- 10. Eye protection.** Always wear safety glasses when using and cleaning this machine.
- 11. Before sandblasting lock doors.** Always lock cabinet doors shut before beginning sandblasting.
- 12. Dust hazard.** Sandblasting causes hazardous dust, which may cause long term respiratory problems if inhaled. Always use a dust collector when using the machine.
- 13. Ensure** the label and Safety Data Sheets (SDS) of all abrasive blasting mediums used is checked for suitability and safe use and any extra control measures needed are put in place before their use.
- 14. Call for help.** If at any time you experience difficulties, stop the machine and call you nearest branch service department for help.

PLANT SAFETY PROGRAM

NEW MACHINERY HAZARD IDENTIFICATION, ASSESSMENT & CONTROL

Sandblast Cabinet

Developed in Co-operation Between A.W.I.S.A and Australia Chamber of Manufactures
 This program is based upon the Safe Work Australia, Code of Practice - Managing Risks of Plant in the Workplace (WHSA 2011 No10)

Item No.	Hazard Identification	Hazard Assessment	Risk Control Strategies <small>(Recommended for Purchase / Buyer / User)</small>
F	STRIKING	LOW	Make sure all guards and doors are secured shut when machine is on.
G	HIGH PRESSURE AIR	MEDIUM	Make sure all guards and doors are secured shut when machine is on. Disconnect air supply to machine prior to checks or maintenance.
H	ELECTRICAL	MEDIUM	All electrical enclosures should only be opened with a tool that is not to be kept with the machine.
O	OTHER HAZARDS, NOISE, DUST.	MEDIUM	Wear hearing protection as required. Wear safety glasses as required. Ensure Sandblast Cabinet is connected to appropriate Dust Collector as required Ensure the label and safety Data Sheet (SDS) of all Abrasive Blasting Mediums used are checked to be suitability and Not Containing Restricted Hazardous Chemicals above Regulatory Safety Levels. Also ensure Safe use and any extra control measures needed are put in place before their use.
Plant Safety Program to be read in conjunction with manufactures instructions			



www.machineryhouse.com.au



www.machineryhouse.co.nz

Authorised and signed by:
 Safety officer:
 Manager: 

Revised Date: 7th June 2016